FEED

MAKE EVERY MINUTE COUNT





CONTENTS

Introduction	4-5
Feed	6-7
Forage Wagons	8-9
Giltrap Forage Wagons	10-15
Buckton Forage Wagons	16-18
Quick Hitch	19
Bale Feeders	20-21
RS2 Feeders	22-23
G2X2 Bale Feeders	24-25
G2 Round Bale Feeders	26-27
Bale Buggy	28-29
MultiPlus Feeders	30-33
From Seed to Feed	34
Global Presence	35

ENGINEERED PERFORMANCE

Experience tells us that time is the scarcest commodity on your farm.

To give you more time, we focus our energy on understanding the mechanics of your daily farm routines to engineer solutions that are in sync with your operations.

It started with Wilfred Giltrap making bespoke machinery from his Otorohanga shed in 1959. Building on his high standards, the shed has grown and so has our team's understanding of what it takes to build serious farm machinery. Together, we're building on Wilfred's legacy, obsessing over the details to design and manufacture robust equipment that is stronger and gets work done better and faster.

Our design process starts on the land, listening to farmers and growers. The things we hear and the insights we gather are then combined with generations of engineering experience and an understanding of what technology has to offer.

Through this process ideas are transformed into schematics and raw materials are engineered to create finished machinery. Before each machine makes it onto your farm, it's put through its paces on our unique test facilities - on real New Zealand farms - to ensure each piece of kit lives up to the Giltrap reputation for strength, innovation and legendary durability.

It's all part of our promise, that as long as it's on your farm, a Giltrap machine will be in sync with your routine and make every minute count.

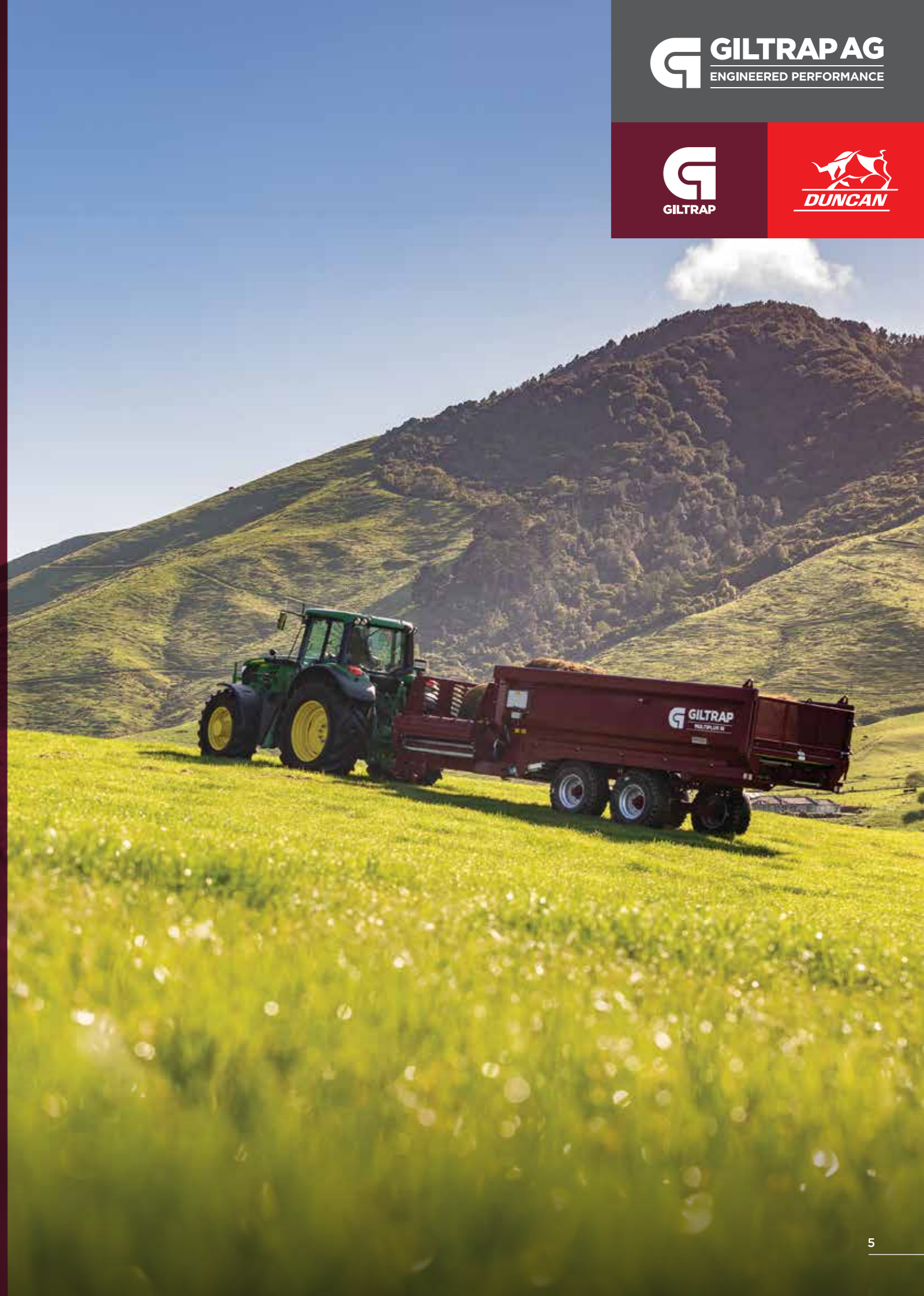

FEED

Our engineers ensure that robust and proven designs are combined with precise feed control and electronic weighing options to help you deliver on your feed programmes with total accuracy.



GILTRAP FORAGE WAGONS

For farmers looking for next-level technology in accuracy and capacity at feedout, look no further than Giltrap Forage Wagons - the premium brand that introduced farmers to hydraulic load sensing and wireless weighing technology generations ago. Suited to all farm sizes and workloads, with capacity from 9 to 25 cubic metres. Stacked with other great standard features such as stainless steel sides, mudguards and LED lights. Backed with a three-year warranty, you'll soon see why Giltrap Forage Wagons are regarded as the premium choice.



BUCKTON FORAGE WAGONS

Buckton Forage Wagons offer farmers the choice of performance at good value. Developed by the Buckton family five decades ago for farmers looking for a functional, durable, easily maintained and operated machine at a competitive price. Built in the Giltrap factory to the same high standards as Giltrap wagons, Buckton Forage Wagons come in nine models in either a side or centre feed configuration, backed by a full 12 month warranty and packed with time-tested, proven features to advance your herd's nutrition.



QUICK HITCH

To keep things moving efficiently we have designed a strong and robust Quick Hitch to make life easier and save you valuable time. A range of clever features makes this Quick Hitch a must-have on your farm.



BALE FEEDERS

Discover our meticulously crafted Bale Feeders, designed to revolutionise feed time with unparalleled ease and efficiency. These precision-engineered machines grant you absolute control over portion size, enabling swift delivery of both round and square bales of hay or baleage across any terrain without any wastage. Experience the ultimate convenience and productivity as you effortlessly provide nourishment to your livestock with our top-of-the-line Bale Feeders.



MULTIPLUS FEEDERS

Farmers can count on the unmatched versatility of a Giltrap MultiPlus Feeder to handle a wide range of feed types with ease. From chopped bulk silage to square bales, chopped round bales, maize, and even fodder beet, these feeders are your reliable solution to get the feeding out done. Rest assured that with Giltrap MultiPlus Feeders, you have a durable and dependable machine for all your feeding needs.



FORAGE WAGONS

We have two great brands for you to choose from so you can find something that fits your farming needs at a price that's right for you.

GILTRAP FORAGE WAGONS

Since the 1970's Giltrap has become synonymous with forage wagons and has remained at the forefront of innovation and groundbreaking concepts. As the industry has changed and grown, farmers have become accustomed to our ability to adapt to those changes and continually strive for design excellence and the introduction of new technologies. Join the countless satisfied farmers worldwide who have made Giltrap their trusted choice for top-quality forage wagons.



BUCKTON FORAGE WAGONS

Fifty years ago, with an acute understanding of farmers' needs for functionality and durability, the Buckton family developed their range of forage wagons. Today, Buckton Wagons remain the top choice for farmers seeking a perfect blend of agility, long-proven reliability, user-friendly operation, and easy maintenance - all offered at a highly competitive price. Buckton owners continue to enjoy the exceptional performance and unbeatable value a Buckton Forage Wagon brings to their business.



THE NAME IN FORAGE WAGONS

Giltrap Forage Wagons have become a legacy brand on the farm for good reason. For 50 years farmers have told us what they wanted in a forage wagon, and today's Giltrap Forage Wagons are the result.

Farming is very different today to what it was 50 years ago, and the success of our Giltrap wagons is not just a product of our ability to listen to farmers' needs, but also to stay one step ahead.

Simple to use while delivering exceptional agronomic performance, Giltrap Forage Wagons take the nutritional outcomes of your farm to the next level. Our extensive range is built to handle all feed types from grass, maize, whole crop cereal and silage, to long and precision-cut, round or square bales for all farm sizes.

Giltrap is and has always been a leader in introducing industry-leading technology. Farmers requiring more from their forage wagon can choose from a broad range of options and accessories, such as wireless weighing and feed rate automation for precise control. We recommend talking to your local dealer and/or your farm advisor to settle on the model specifications you require.



KEY FEATURES	BENEFITS
Strong rugged design and construction	Will provide years of service in tough conditions
Minimal and simplified maintenance with cast iron bushes instead of ball bearings on high load shafts, and stainless steel chain tensioners	Hard-wearing and long-lasting. Impervious to dirt, grit and silage moisture
High-tensile calibrated link chains on the floor and elevator don't need any maintenance and won't seize in the acidic silage environment	Long-lasting with superior strength for heavy loads
Large profile high-tensile cast chain sprockets are designed for maximum chain engagement and low wear	Long life high torque drives on floor and elevator chains
Stainless steel sides provide strength with flexibility	Reduces corrosion and wear and tear
Heavy-duty walking beam axles with replaceable Vesconite™ pivot bushes. Vesconite™ has built-in lubricants	Low friction and long-lasting, even where no lubrication is applied
Oversized stub axles with sealed hubs	Extended life in demanding and wet conditions
Load sensing hydraulics ensure an even feed flow is maintained. Feed rate is adjusted manually and can be upgraded to wireless and automatic rate control linked with the optional weighing system	Precise feed management
All wagons are 'scale-ready' with a double chassis and load cell mounting points	Flexibility to upgrade to RF wireless scales if required
Mesh front screen and mesh rear back gate	Improves visibility and load monitoring
Extra heavy-duty elevator bars and floor slats with secure chain attachment	Built for heavy, tough loads. Easy to service or replace
Extra-large side delivery opening, and wide belt caters for a large variety of feed products	Reduces blockages and allows easy access for servicing. Great for feeding bales
Internal bearings on the cross conveyor	Prevents wrapping, protects from mud thrown off the tractor tyres and minimises maintenance
Centralised greasing point system	Easy maintenance
High pressure trip mechanism on the back gate	Reduces the risk of gate damage when reversing the floor
Ladder, walkways and LED tail lights	Improves visibility, operator safety and bin access while keeping dirt and mud spray to a minimum
Swivel towing eye	Enhanced towing and improved operator safety

GILTRAP FORAGE WAGONS CONT.



Minimal and simplified maintenance with cast iron bushes instead of ball bearings on high load shafts, and stainless steel chain tensioners



High-tensile calibrated link chains on the floor don't need any maintenance and won't seize in the acidic silage environment. 35mm T&G treated pine flooring. Time proven durability in a harsh, corrosive environment



High-tensile alloy forged links form part of the elevator chain assembly providing a rigid two-bolt fastening system for the elevator bars



Stainless steel sides for corrosion and wear resistance



Heavy-duty walking beam axles with replaceable Vesconite™ pivot bushes. Oversized stub axles with sealed hubs for extended life in demanding and wet conditions



An even feed flow is maintained with load-sensing hydraulics. The feed rate is adjusted manually and this can be upgraded to wireless and automatic rate control linked with the optional weighing system



All wagons are 'scale-ready' with a double chassis and load cell mounting points



Mesh front panel for visibility into the wagon



Large 900mm or 1200mm wide belt for easy discharge of bales



Centralised grease banks for easy greasing of elevator bushes, sprockets and axle components



Simple chain and sprocket double reduction powers the floor chains and is very simple to maintain



Ladder, walkways, and LED tail lights. Bin access/operator safety/ keeps dirt and mud spray to a minimum/on road visibility

WIRELESS TECHNOLOGY (OPTIONAL)

RF WIRELESS SCALES AND FEED RATE AUTOMATION

Our wireless scale and control technology was the first of its kind and used to relay wagon data to the monitor mounted in the tractor. Designed and manufactured by Giltrap specifically for forage wagons, and with proven in-field reliability. This system integrates scales and hydraulic feed rate control.

Controller has large push button function keys and an easy-to-read backlit display. Allows the user to monitor weight changes and make informed decisions from inside the tractor, and has an operating range up to 100m or line of sight.

Supports constantly-changing farming management practices including better feed utilisation. Provides confidence that the correct ration portions are fed out.

Digital display mounted inside the cab ensures accurate loading no matter the weather conditions – no need for guesswork as the scales are at your fingertips while loading the wagon.

The robust design is configured with either 4 or 6 industrial shear beam load cells and heavy-duty mounts. Bespoke stainless convex/concave pivot washers ensure accurate scale readings on the move.

GREAT TECHNICAL FEATURES SUCH AS:

- Programmable low battery warning with on-screen display
- Programmable automatic shutdown function to conserve the battery life
- Automatic charging of the on-board 12 volt battery
- Compact, sturdy tractor mounting bracket with on/off switch
- Easily accessible service junction box
- Plug-in service modules
- Controller module fitted with external function LEDs for simple user information and diagnostics
- Controller can easily be shifted between tractors with the addition of a second bracket and power loom

CHOOSE AN OPERATION MODE TO SUIT YOUR FARM

Scales – The feed load in the wagon is displayed with tare and gross scale functions at your fingertips, and the feed rate is controlled manually. Requires load cells.

Standard Control – Upgrade from manual control so that the feed rate can be adjusted with the controller from the tractor seat on the move – particularly useful for feeding out large bales. Requires solenoid valve. Load cells optional.

Weight Control – Set and feed target weight limit from the tractor seat. The wagon will sound an alarm and stop floor movement when it reaches the target, and the technology enables you to stop, start and adjust the discharge rate while on the move. Requires solenoid valve and load cells.

Speed Control – Add a wheel sensor for ground speed compensation and make paddock feeding easier. Undulating terrain is compensated for by automatically adjusting the feed rate while you drive. Feed rate can be adjusted with the controller from the tractor seat and is automatically adjusted according to ground speed. Requires solenoid and wheel sensor. Load cells optional.

Distance Control – Upgrade to wireless scales with fully automatic control. Simply enter your total feed pad length and how much you want to feed out, and the wagon does the maths.

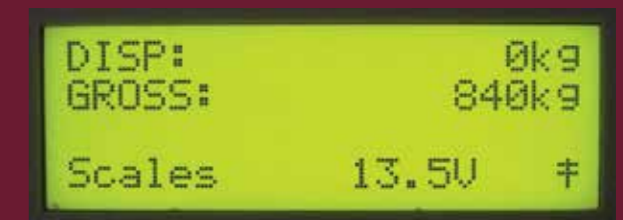

GILTRAP FORAGE WAGONS CONT.

OPTIONAL EXTRAS

- Tyre options. There are various tread patterns and ground pressure properties to choose from for your specific needs. Tyre upgrades typically fitted to Forage Wagons include;
 - a) 400/70R22.5 x 8 stud - large rolling diameter, high load rating and good for road and concrete use. The narrow profile and tyre construction are less suitable for soft ground
 - b) 500/45-22.5 x 8 stud - very good low profile flotation tyre ideal for soft conditions
 - c) 500/60-22.5 x 8 stud - similar to the 500/45-22.5 but with a larger rolling diameter and higher load rating
 - d) 560/60R22.5 radials x 8 stud - heavy-duty radial construction which performs well in road use and soft ground
- Drum brakes - typically fitted to the front axles but can be added to all wheels if desired. Hydraulically actuated from the tractor - increased safety
- Brake upgrade from hydraulic activation to air activation - increased safety/suitable for many late model tractors operating at higher towing speeds
- Brake line pressure relief valve block for remote service activated brakes - provides adjustment to hydraulically-activated brakes to reduce the chance of brakes locking up
- 16.5T or 21.5T sprung axle (rear steering) fully hydraulic brakes - improved manoeuvrability/ideal for longer distance road travel at higher speeds/reduces chassis fatigue and rear tyre scuffing
- 16.5T or 21.5T sprung axle (non-steering) fully hydraulic brakes - ideal for longer distance road travel at higher speeds/reduces chassis fatigue/smooth ride
- Raising blocks (150mm) RF9 or RF11 models only. These bolt between the axle mounts and the chassis giving extra clearance height to feed into feed troughs
- K80 ball hitch (spoon attachment in lieu of swivel towing eye). Provides secure attachment/safety/greatly reduced wear on the trailer connection point
- Extra scale monitor cradle and wiring loom - easily transfer the monitor between tractors
- Hydraulic jack - ideal for large wagons instead of a manual wind jack
- Quick hitch stand - ideally should be used in conjunction with a Giltrap Quick Hitch. Fast hitching and unhitching/less likely to damage jack stand/safety/reduces chance of drawbar sinking
- Rear strobe light - safety with improved visibility
- Conveyor autoshift ram with 200mm movement. Extends the cross conveyor past wheel assemblies to reduce the likelihood of feed being run over
- Chain and slat conveyor - ideal for use with large square bales or beet. Well suited for large volume feeders. Excellent tracking and low maintenance
- Cross conveyor extension with adjustable discharge height. 900mm length to 2100mm length. Precise product delivery into feed pads/troughs/feed rings
- 4-chain elevator with gearbox drive (std on RF25) for extended life on high use machines
- Gearbox elevator drive on 2-chain elevator - gives a positive drive with smooth high torque power transmission
- Over width panels on tail gate - safety with increased visibility on the road



Folding cross conveyor extension



QH stand



Autoshift ram extends the conveyor 200mm



Chain and slat feedout conveyor



Gearbox elevator drive



Front brakes (std in RF21 & RF25)



DIMENSIONS AND CAPACITIES

MODEL	RF9	RF11	RF13	RF16	RF21	RF25
Overall length (m)	6.075	6.075	7.475	7.475	9.200	9.400
Overall width (m)	2.530	2.530	2.750	2.750	2.800	2.850
Overall height (m)	2.610	2.790	2.610	2.790	2.920	3.270
Loading height (m)	2.200	2.440	2.200	2.440	2.570	3.060
Bin length (m)	3.800	3.800	5.200	5.200	6.400	6.400
Bin height (m)	1.230	1.470	1.230	1.470	1.600	1.930
Bin width (m)	2.050	2.050	2.050	2.050	2.050	2.050
Tare weight (kg)	2470	2620	3290	3750	4650	5680
Cubic capacity (m ³)	9	11	13	16	21	25
Conveyor belt width (mm)	900	900	900	900	1200	1200
No. of floor chains	2	2	4	4	4	4
Load cells (kg)	4 x 5000	4 x 5000	6 x 5000	6 x 5000	6 x 5000	6 x 5000
Jack type (mm)	80 screw	80 screw	80 screw	80 screw	80 screw	80 screw
Axle type	Tandem	Tandem	Tandem	Tandem	Tandem	Tandem
Axle size (mm)	60 (6 stud)	70 (6 stud)	70 (6 stud)	80 (8 stud)	90 (8 stud)	90 (10 stud)
Wheels	11.5/80 x 15.3	11.5/80 x 15.3	400/60-15.5	400/55-22.5	500/60-22.5	500/60-22.5

BUCKTON FORAGE WAGONS

Buckton Forage Wagons are perfect for the farmer who appreciates simplicity, strength and reliability all bundled into a cost-effective package.

With nine models from 8.3 to 20 cubic metres capacity and your choice of side discharge or centre feed delivery, there's a Buckton wagon to suit your herd's nutrition needs. Delivering precise and even feed rates, these wagons will handle most types of fodder including chopped round bales, green feed crop, long or fine chopped silage and other fine-grained supplement feeds.

Every model is packed with proven features so that you know the wagon will keep doing the job for you, day in and day out. Customise every model from a long list of options for added functionality to suit your farm.

KEY FEATURES

- The pressed steel chassis and steel hollow section sub-frame are light but extremely strong, with torsional strength under high loads and challenging terrain
- Feed rates and placement are easily controlled with our hydraulic load sensing system. The side delivery conveyor runs at a constant speed to put feed accurately on a fence line or into feed bins. The chain floor automatically changes as the load is fed out to maintain a steady feed rate
- Buckton wagons will operate on most tractors, with only one set of double-acting hydraulics needed to drive the feed mechanisms
- Heavy-duty walking beam axles with replaceable Vesconite™ pivot bushes. Vesconite™ has built-in lubricants that translate into low friction and long life, even where no lubrication is applied
- Over-sized stub axles with sealed hubs give great service in demanding and wet conditions
- Large diameter high-tensile driveshafts running in bronze bushes are low maintenance and very reliable
- The rear gate has a spring-loaded latch which automatically opens to protect the gate if the floor is accidentally reversed
- Swivel tow coupling on the drawbar aids stability and dramatically reduces the risk of tractor rollovers on hilly terrain



The durable hardwood floor and stainless steel sides protect against the corrosive effects of silage



The heavy duty 900mm wide rubber belt will handle all feed products. Feed placement is controlled with adjustable belt speed



The conveyor position can be easily adjusted by up to 250mm for extra reach into feed troughs



Easily adjustable load sensing rate control and conveyor speed lets you set the feed rate and control where the feed lands on the ground



Low-maintenance, high-torque gearboxes are used on the floor and elevator drives for reliable power transmission



Full width floor slats ensure each load is fully cleaned out to minimise wastage. Slats are mounted to high-tensile calibrated link chain which has been proven for years in the gritty acidic silage environment, without rusting and seizing like roller chains



Floor and elevator chains are easily tensioned with stainless steel chain adjusters that won't corrode and seize



Spring-loaded trip on rear door catch



The galvanised ladder provides access to reach over the sides for adding minerals or supplements to the load



BUCKTON FORAGE WAGONS CONT.

OPTIONAL EXTRAS

- Electronic scales with wagon-mounted display to assist with feeding the correct quantities
- Optional in-cab remote scale display
- Electronic feed rate control from the tractor seat. Useful if you need to make frequent rate adjustments
- Hydraulic side-shift ram for the conveyor bed lets you adjust the conveyor position from the tractor cab for extra reach into feed bins
- Remote greasing system for axle pivot bushes to aid with easy maintenance
- Hydraulic drum brakes for front and rear axles
- LED tail lights
- Hydraulic jack
- Quick Hitch skid to use with a Quick Hitch pick-up system
- Lifting blocks on the axle (150mm). Lifts the conveyor belt height for better reach into feed bins
- Mudguards
- Single axle for better manoeuvrability and reducing tyre scuffing on concrete feed pads



Side shift ram



Scale screen



QH Skid

DIMENSIONS AND CAPACITIES

MODEL	SD83	SD100	SD130	SD160	SD200	CF83	CF100	CF130	CF160
Length (m)	5.97	6.55	7.77	7.77	9.09	5.97	6.55	7.77	7.77
Height (m)	2.70	2.70	2.70	2.95	2.95	2.70	2.70	2.70	2.95
Width (m)	2.60	2.60	2.60	2.80	2.95	2.60	2.60	2.60	2.80
Capacity (m ³)	8.3	10	13	16	20	8.3	10	13	16
Tyre size	11.5/80x15.3	11.5/80x15.3	400/60x15.5	400/55x22.5	400/55x22.5	11.5/80x15.3	11.5/80x15.3	400/60x15.5	400/55x22.5
Axle	Tandem	Tandem	Tandem	Tandem	Tandem with front brakes	Tandem	Tandem	Tandem	Tandem
Axle size (mm)	60 (6 stud)	60 (6 stud)	70 (6 stud)	80 (8 stud)	80 (8 stud)	60 (6 stud)	60 (6 stud)	70 (6 stud)	80 (8 stud)
Weight (kg)	1890	1945	2320	2670	3800	1480	1775	2070	2500
Bin size	3.2x1.22x2.14	3.82x1.22x2.14	5.20x1.22x2.14	5.20x1.49x2.14	6.42x1.49x2.14	3.2x1.22x2.14	3.82x1.22x2.14	5.20x1.22x2.14	5.20x1.49x2.14
No. of floor chains	2	2	2	2	4	2	2	2	2
Optional load cells (mm)	3x54	3x54	3x73	3x73	6x54	3x54	3x54	3x73	3x73
Jack type (mm)	80 screw	80 screw	80 screw	80 screw	80 screw	80 screw	80 screw	80 screw	80 screw

GILTRAP QUICK HITCH

The Giltrap Quick Hitch helps you seamlessly connect to your towed implement in a way that won't compromise your load capacity or manoeuvrability.



The Giltrap Quick Hitch is robust and well designed to give you years of faultless service. The recessed tow pin closely mimics the position that a regular tow bar would be, thus maintaining good stability of the towed implement.

KEY FEATURES

- Interchangeable Category 2 tow pin for trailers up to 12 tonnes
- Wearalloy plate where the towing eye rests
- Clear view to pin and latch when sitting in the tractor seat
- Spring loaded safety latch locks the tow eye into place
- 32mm centre bar for maximum strength
- Clevis-style pin connection for long-lasting durability
- Fully powder coated for a durable finish

OPTIONAL EXTRAS

- Category 3 tow pin for trailers up to 18T

DIMENSIONS AND CAPACITIES

Overall length (mm)	345
Overall width (mm)	1000
Overall height (mm)	846
Weight (kg)	76



Clevis pin connection



Interchangeable tow pin - can be Cat 2 or 3



Clever design allows for tight turns

BALE FEEDERS

We've designed our bale feeders to make feed time quick and easy.

These finely tuned machines ensure that you have complete control over portion size and can quickly deliver round or square bales of hay or silage across all kinds of terrain, with no waste.

RS2 FEEDER

The Giltrap RS2 Feeder can efficiently feed out different variations of round and square bales. The RS2 is built to Giltrap's high standard for reliability and long-life performance.



G2X2 BALE FEEDER

Feeding a lot of bales doesn't have to take a long time. The G2X2 is quick to load and safe to use. Designed to feed out all types of round bales, including wrapped silage, hay and straw.



G2 ROUND BALE FEEDER

The G2 linkage-mounted feeder is designed to feed out all types of round bales, including silage and hay. The cradle design has a low centre of gravity and keeps the bale securely in the machine, making it great for working on and around hills.



BALE BUGGY

Don't have a tractor, or you don't want to tie up your big tractor feeding the stock? No problem. Our Bale Buggy will feed out all types of hay, straw or silage round bales - no tractor or hydraulics required!



RS2 FEEDERS

Versatile performance for loading and feeding out two large square or round bales - safely and efficiently - day in, day out.

Two-stage sequence hydraulic lifting gives complete control of bale loading and allowing twine and plastic to be removed over the feed bed while reducing wastage. You'll be hard pressed to find a stronger built, smoother functioning, longer lasting and better value bale feeder than the Giltrap RS2!



The controlled loading headstock can be paused above the feed bed for easy removal of net and wrap



The extra wide 2.2m wheel track keeps the RS2 feeder stable on rough ground and hills



Convenient large capacity string box is standard, with a hinged lid to hold large volumes of net or plastic



High-tensile 6mm folded channel tine bars have super aggressive tapered teeth to tear and release tightly baled feed. Bolted to 3" 15000lb solid pin chain



Large displacement motor guarantees power to keep heavy bales turning - driveshafts enclosed for less chance of wrapping



The swivel tow hitch can be adjusted for drawbar height. Complete with jack stand



Optional Clevis-style hitch



Optional mudguard set

OPTIONAL EXTRAS

- Mudguard set
- Flotation 400/60-15.3 wheel upgrade assemblies
- Traction 11.5/80-15.3 wheel upgrade assemblies
- Third bale tine for headstock
- Bed extension for 8" square bales
- Elevator extension for extra reach
- Clevis-style hitch

KEY FEATURES

Carries 2 x big squares up to 8ft or round bales of up to 6ft

Controlled stage HD headstock loading system - for easy net/plastic removal above the bed

3" 15000lb solid pin chain with HD bolted tine bars

Bale spike headstock with optional 3rd fork

Heavy-duty steel feedout cradle with unique centralised pivot system

Wide wheel track width of 2.2m

Large string box with hinged lid

Fully enclosed shafts

Quality brand, high profile tyres come standard!

Minimal moving parts and pivot points bushed and greaseable

Swivel tow eye with adjustable hitch height, perfectly match drawbar height

BENEFITS

Gets the job done with ease on all types of bales while saving you valuable time

Reduces waste

Improved tearing action of tight bales with more durability and longevity

Allows for faster, more effective loading of square and round bales. (note 3rd fork std in Australia)

Safety and reliability while handling big heavy bales

Added stability

Holds large volumes of crop packaging securely while you feed out

Reduces chance of wrapping

More flotation and longevity

Low maintenance and long service life

Optimum feeding performance

DIMENSIONS AND CAPACITIES

Overall length (m)	4.83
Overall height (m)	2.03
Transport width (m)	2.42
Axle track width (m)	1.93
Weight (kg)	1510
Max. round bale size (ft)	6 (dia)
Max. square bale size (ft)	4x4x8 with extension
Max. bale weight (kg)	1500
Axle size (mm)	50 (6 stud)
Wheels	11.5/80-15.3
Hydraulic requirements	2 services

G2X2 BALE FEEDERS

Trusted and proven performance for feeding out round bales safely, efficiently, and reliably day in, day out.

The stainless steel lined cradle design is both smart and robust with a low centre of gravity while retaining round bales securely. Two-stage sequence loading gives total control of loading and removing twine and plastic, saving you more of your valuable time and fodder. You'll be hard pressed to find a stronger, smoother-functioning, longer lasting, better value trailed bale feeder than the Giltrap G2X2!

KEY FEATURES

- Carries 2 x round bales of up to 6ft – gets the job done with less travel - saving you time. The tapered teeth on 6mm zinc-plated bars are aggressive but release feed cleanly
- 2-stage HD headstock hydraulic loading system – total control of bales allowing easy net/plastic removal and soft loading into the feed cradle
- Large diameter pivot pins with replaceable bronze bushes on the lift system pivots
- 3" 15000lb solid pin chain with HD bolted tine bars – improved tearing action of tight bales with more durability
- Full width stainless steel bed contains chopped bale material and won't rust out over time
- Bale spike HD headstock with 2 position setting – allows for faster more effective loading of 4ft - 6ft bale heights
- Feeds from either side – versatility in directing fodder, while handling not-so-perfect bales
- Wheel track width adjustment of 120mm each side – for added stability in undulating conditions
- Large string box with hinged lid standard – holds large volumes of crop packaging securely and has a recess for cutting device storage
- Fully enclosed shafts – reduces chance of wrapping
- Quality brand high profile tyres – more flotation and longevity
- Swivel tow eye with adjustable hitch height – perfectly match drawbar height for optimum feeding



Two loading position settings allows for fast accurate loading of different bale sizes between 4 ft and 6 ft



HD high-tensile 6mm U-profile folded tine bars bolted to 3" solid pin chain have a super aggressive taper to tear and release the tightest of bales



The low centre of gravity and extra wide wheel track keep the G2X2 feeder stable on hills. The wheel track is adjustable to 240mm in total



Convenient large capacity string box is standard with hinged lid, holds large volumes of net or plastic



Large displacement motor guarantees power to keep heavy bales turning – driveshafts enclosed for less chance of wrapping



Adjustable tow eye hitch to match drawbar height for optimum feeding. Complete with integrated jack stand



The 15000lb chain can be tensioned as it wears with rotating cam bushes



G2X2 feeders have a stainless steel floor for corrosion protection and long life

OPTIONAL EXTRAS

- Flotation tyre upgrade 400/60-15.3
- Traction tyre upgrade 11.5/80-15.3

DIMENSIONS AND CAPACITIES

Overall length (forks up) (m)	4.10
Overall height (m)	1.06
Overall width (m)	1.98
Weight (kg)	942
Feed chain (lb)	15000 3"roller
Hydraulic drive	2 x remote acting
Axle type	Single axle
Axle size (mm)	50 (6 stud)
Wheel type	11.5/80-15.3 12 ply
Bale weight rating (kg)	2 x 1500

G2 ROUND BALE FEEDERS

With its low centre of gravity and robust build, the G2 round bale feeder is designed to feed out any round bale - and the odd square one, anytime, anywhere!

The stainless steel lined cradle design is both smart and robust with a low centre of gravity and being able to connect the headstock with bale loading tines from either end, will save more of your valuable time.

You'll be hard pressed to find a stronger smoother functioning, longer lasting, better value linkage bale feeder than the Giltrap G2!

KEY FEATURES

- 3-point linkage headstock complete with bolted-on high-tensile steel hay tines - strong and compact, a complete loading and feeding solution
- Feeding cradle is designed to be driven and loaded on either end - makes loading a breeze and saves more time
- Feeds out either side - versatility in directing fodder and handles not-so-perfect bales
- Locking headstock latch with optional hydraulic latch - quick cradle coupling will save you time and money
- Full width stainless steel bed - retains valuable fodder and enhances durability and service life
- Fully enclosed shafts - reduces wrapping and increases reliability
- No ball bearings - all shafts run in greasable cast iron bushes which are impervious to dirt and moisture and will provide a very long service life



Headstock with cradle drive and bolted tines have one longer tine for reconnecting easily. Heavy profile plates carry the weight of the cradle/bale without overloading the tines



6mm steel feed tine bars have aggressive tapered teeth to tear and release the tightest most difficult-to-feed bales. The cleverly designed spacing of tine bars maximises the bale feeding efficiencies!



6-tooth cast sprockets with HD motor drive lugs drives 3" high-tensile roller chain



External stainless steel adjusters make feed chain tensioning easy



Spring-loaded locking pin securely latches the headstock to the feeding cradle. Standard release latch is by rope or optional hydraulic latch



Hydraulic motor drive is mounted in the confines of the headstock out of harm's way



The optional hydraulic latch kit makes it easy to release the headstock from the cradle



There's a dog drive connection on both ends of the feeding cradle to speed up the loading process

OPTIONAL EXTRAS

- Hydraulic ram latch kit

DIMENSIONS AND CAPACITIES

Overall length (m)	1.74
Overall height (m)	1.02
Overall width (m)	2.03
Weight (kg)	520
Feed chain (lb)	7500 3"roller
Hydraulic drive	Yes
3-point linkage	Category 2
Fork tine type	2-1/4"high tensile

BALE BUGGY

Tow it behind a road vehicle or side-by-side ATV. The buggy is ground-driven, uses a winch for loading bales and is designed to feed out with minimal pasture damage because you don't need a tractor.

Feed is distributed behind the Bale Buggy as you drive forward, but the reduction gear ratio ensures that the feed mat is broken up so that it's not wasted by animals trampling it into the ground. The powder coated frame and aluminium side panels not only look great, but will provide years of maintenance-free use.

KEY FEATURES

- Handles all types of round baleage
- Feeds out to the rear, with even feed flow so that baleage doesn't get caught up in the chains
- Feed chains are geared 3 x slower than ground speed, so the feed mat is not continuous, and reduces the torque load on the ground drive wheel to reduce slippage in muddy conditions
- The bale weight is forced forward while feeding which keeps load on the drawbar for traction on the towing vehicle, and reduces the risk of the bale falling off the back going up hills
- Easy-to-use bale loading system
- No tractor hydraulics required
- You don't have to feed out the whole bale in one go. Put it away in the shed until you need to feed out some more. Perfect for small farm blocks



A polyethylene guard is fitted to ensure feed does not get caught in the chains or the drive mechanism



The teeth on the bars are offset to ensure even feedout of the bale. They are also tapered to release the feed easily



2-speed winch for ease of loading bales

HOW IT WORKS



Reverse the Bale Buggy to the round side of the bale



Release the winch and tilt the cradle onto the ground. Attach the two bale hooks to the winch stop. Using the hooks pull the stop out and over the back of the bale and push the hooks into the lower part of the bale



Begin to wind the geared winch which in turn will roll the bale into the cradle. When the bale enters the Bale Buggy, its weight will over-centre and the cradle will fall back into its transport position. Finish winding the stopper to its stopper and re-stow the hooks



When you get to the paddock you want to feed out in, engage the ground wheel drive and you are read to go feeding. The bale will gently unroll over the back of the Bale Buggy at a ratio of 3:1 slower than your ground speed

DIMENSIONS AND CAPACITIES

Overall length (m)	3.40
Overall height (m)	1.52
Overall width (m)	2.15
Weight (kg)	433
Feed chains	8mm high-tensile link
Max. bale size	1.80 (dia) x 1.35m

MULTIPLUS FEEDERS

It doesn't matter what feed you are dealing with on your farm, the Giltrap MultiPlus will handle it all with ease.



Round and square bales of hay or silage, pit silage, maize, palm kernel and fodder beet, the MultiPlus will feed it all out. The MultiPlus comes in a range of sizes from 13 cubic metres to 19 cubic metres so there is a machine for every sized operation.

The MultiPlus has two options for feeding out, either with the tilting elevator or the optional bale shredder. The tilting elevator is excellent for feeding out all types of feed onto the ground or into a trough. The load sensing valve on the cross-floor feed bed ensures a consistent and even amount of product is going out over the elevator. The optional shredder on the left hand side is brilliant for ripping up those tightly wound round bales and feeding them out in a nice neat windrow on the ground.

KEY FEATURES

- Will handle the majority of feed types for operational flexibility
- Can feed out both sides for maximum versatility
- Can feed into troughs with the elevator - great for feed pads and barns
- Slat and chain main floor allows the load to be reversed
- Hardox™ floor in the main bed for excellent wear and strength
- Strenx™ sides for ultimate strength
- Rate control on the cross-floor chain is via a load sensing valve for an easily controlled feed rate
- Gearbox drives on both floors for a smooth positive drive
- Heavy-duty tandem axles with remote greasing points and Vesconite™ bushes have built-in lubricants that translate into low friction and long life, even where no lubrication is applied
- Stainless steel chain tensioners are easy to access and won't rust
- Full length string rail for tying off bale strings
- Automatic release back gate
- String box with lid to keep your wrap tidy
- Mudguards to help keep the mud on the ground and not on the wagon
- LED lights for use on the road

MULTIPLUS FEEDERS CONT.



Hydraulic tilting elevator allows the feed to be fed out into troughs



Combined Hardox450® and Strenx700® tub body for unmatched structural strength and toughness



The main floor and the cross-floor are driven by high torque hydraulically driven gearboxes that are strong and reliable



Twin floor chains running in a recessed floor. The slats will wipe the floor clean as the load moves forward



Stainless steel chain tensioners are easy to access and won't rust



An automatically releasing back gate prevents damage if the load is reversed. It also swings fully open to load bales from the back



Rope rails run the full length of the body to tie bale twine onto. The twine strips off the bale as the load moves forward



The string box with a hinged lid is ideal for stowing away the wrap, net and string



High-tensile cast sprockets, link chains and cast bush bearings provide a robust feed transfer system

OPTIONAL EXTRAS

- Front axle hydraulic brakes for safety
- Four axle hydraulic brakes for safety
- Bale shredder on left hand side for tearing up the tightly wound round bales
- Hinged gate for above the shredder when it's not in use
- Joystick control for all three functions. (Requires only one hydraulic bank)
- Diverter valve with electric switch. (Requires two hydraulic banks)
- Hazard panels for extra visibility on the road
- Electronic weighing system with wireless display
- Electronic weighing system with machine-mounted display
- Bale manipulator for keeping round bales upright during the transfer to the cross floor
- Safety chains



Optional wireless scales and joystick control



Optional bale shredder

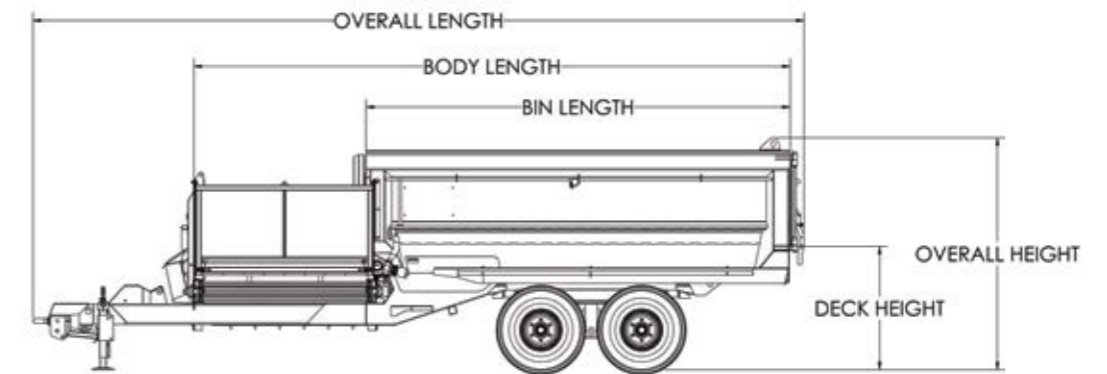

DIMENSIONS AND CAPACITIES

MODEL	MULTIPLUS 13	MULTIPLUS 16	MULTIPLUS 19
4'round bale capacity (mm)	4 x 1800 dia.	5 x 1800 dia.	6 x 1800 dia.
4'x3' square bale capacity	4 up to 7' long (single layer)	6 up to 7' long (single layer)	7 to 7' long (single layer)
Cubic capacity (cu.m)	13.5	16.2	18.9
Est. load capacity (kg)	8700	10400	12000
Bin length (mm)	4165	5365	6565
Body length (mm)	5760	6930	8160
Overall length (mm)	7500	8735	9930
Body width (internal) (mm)	2100	2100	2100
Overall width (mm)	2890	2890	2890
Tandem axle (mm)	70 6 stud unbraked	80 8 stud unbraked	90 8 stud unbraked
Wheels	400/60-15.5	400/55-22.5	500/60-22.5
Suspension	Oscillating beam		
Floor height (mm)	1200	1300	1495
Overall height (mm)	2300	2400	2615
Main bin floor	4 chains/slat moving floor		

FROM SEED TO FEED

That's the Giltrap Ag difference. From hard-working Giltrap machinery to help you feed, spread and carry to Duncan Drills, the world's best drilling technology. We help take the hard work out of producing some of the world's finest pasture and crops.



**WIDETRAC
FERTILISER SPREADERS**



**PRO-SERIES
FERTILISER SPREADERS**



ORCHARD SPREADERS



SLURRY SPREADERS



TIP TRAILERS



CONSTRUCTION TRAILERS



**DUNCAN
DISC DRILLS**



**DUNCAN
TINE DRILLS**

GLOBAL PRESENCE, LOCAL KNOWLEDGE

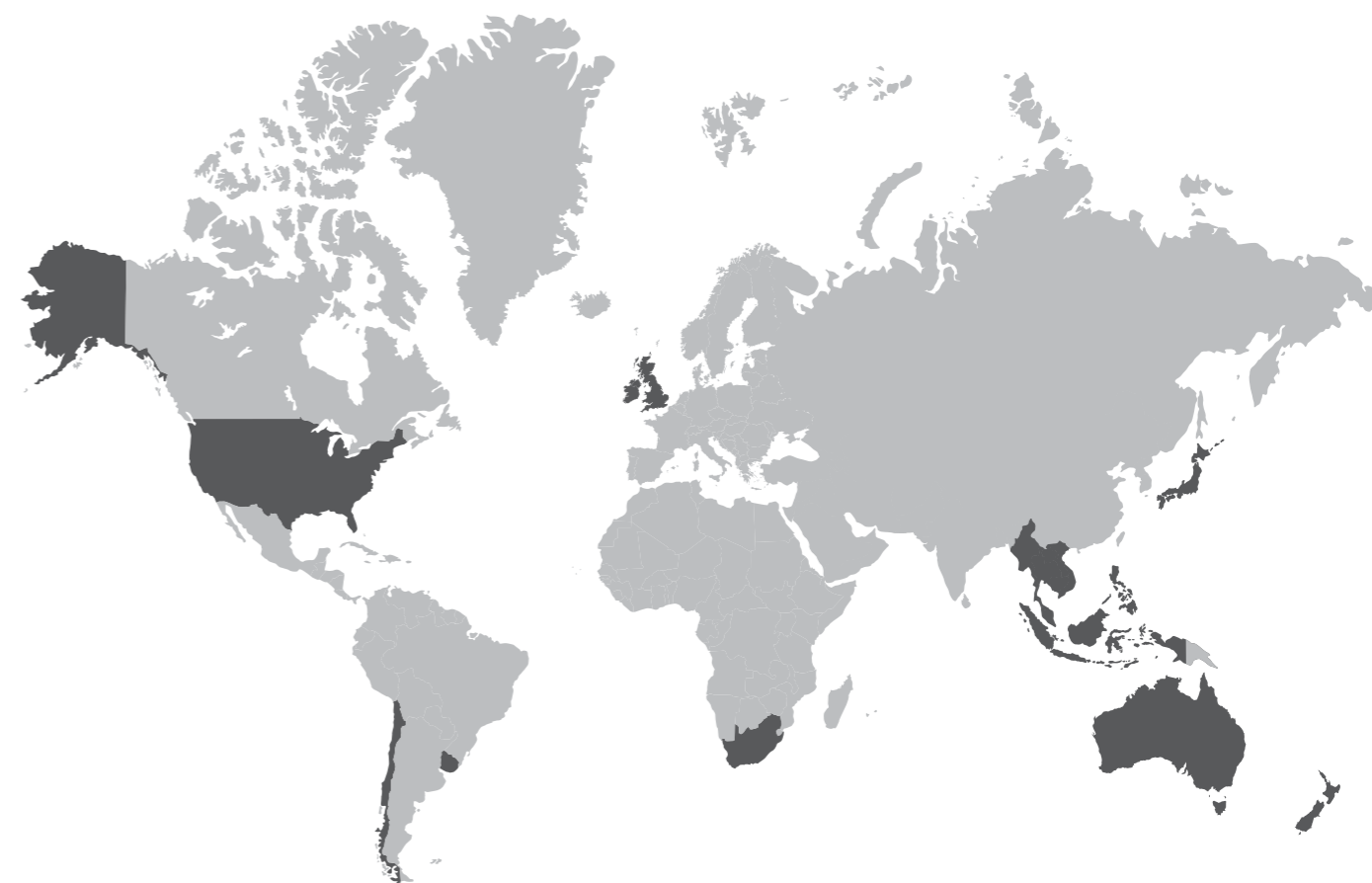

We put so much time and energy into bringing you the best possible product that we aren't going to let this stop when the equipment leaves our factory. With a dealer network around the globe we've made sure you'll get the best ongoing equipment support no matter where you are.

**TO FIND YOUR LOCAL DEALER VISIT
GILTRAPAG.CO.NZ/OUR-DEALERS**

GILTRAP AG
ENGINEERED PERFORMANCE



24/7

We've assembled a comprehensive dealer network that knows what it takes to keep your Giltrap machinery in peak condition. With a blend of local knowledge and engineering expertise our team is here 24/7, so your business doesn't have to stop.

To find out more about our local dealer network or to discuss your specific needs, contact a member of our team.

NEW ZEALAND (HEAD OFFICE)

TEL +64 7 873 4199

EMAIL info@giltrapag.co.nz
giltrapag.co.nz

AUSTRALIA

TEL +61 3 9369 6548

EMAIL sales@giltrapag.com.au
giltrapag.com.au

To find your local Giltrap and Duncan dealer visit
giltrapag.co.nz/our-dealers